

Achieving Success as Vice President Membership

Club Leadership TRAINING PROGRAM



TOASTMASTERS
INTERNATIONAL

THE MISSION OF THE CLUB

The mission of a Toastmasters club is to provide a mutually supportive and positive learning environment in which every member has the opportunity to develop communication and leadership skills, which in turn foster self-confidence and personal growth.



©Toastmasters International®

P.O. Box 9052 • Mission Viejo, California 92690 U.S.A.
(949) 858-8255 • Fax (949) 858-1207 • www.toastmasters.org

TRAINING CLUB LEADERS . . . A VITAL FUNCTION

As a coordinator for club leadership training, you have one of the most important roles in Toastmasters.

The quality of a club meeting determines whether people join and stay in our organization. For a Toastmasters club, success lies in the ability to provide an environment that fosters meaningful self-development for members. This is where officer training comes into play. Club officers must know their roles and responsibilities. The trainer's job is to explain this and to make sure all officers understand why their roles are so important for the overall success of the club. Your effectiveness as a trainer can make the difference between success and failure for a Toastmasters club.

Preparation is the cornerstone of a good training session. Take time to review the handbook, then study the training program thoroughly. Don't forget to inject your own personality and experiences to create a session that is educational, enjoyable, and motivational. Helpful tips to assist in your preparation for this training session are provided in Part I. Part II covers the essential points of the session while Part III provides you with handouts to distribute. Part IV contains copy for visual aids. **This entire training program, including PowerPoint slides, is available for downloading on the Toastmasters International Web site, www.toastmasters.org.**

This program is your comprehensive guide for preparing and presenting an effective club officer training session for the office of vice president membership. By the end of the session, the members of your audience will be familiar with such basic competencies as setting goals for growth, planning a membership building contest, greeting and encouraging guests to join, completing a membership application, ensuring new members receive an orientation and formal induction, increasing member satisfaction, assisting in the preparation of a Dues Renewal Invoice, participating and voting at area council meetings, and preparing their successor for office.

TABLE OF CONTENTS SECTION

CONTENT	PAGE
PART I	PREPARING FOR THE TRAINING SESSION
A. Three Steps in Planning a Successful Training Program	4
B. The Training Environment	5
C. How to Use the Program Outline	6
D. Checklist for Club Officer Training	7
E. Evaluation and Follow-Up	7
PART II	PRESENTATION OF THE TRAINING SESSION
Script	8
PART III	COPIES OF HANDOUTS AND EVALUATION FORM
PART IV	VISUAL AIDS COPY FOR THE TRAINING SESSION

PART I: PREPARING FOR THE TRAINING SESSION

A. THREE STEPS IN PLANNING A SUCCESSFUL TRAINING PROGRAM

1. Prepare the Training Agenda

The information in this manual should be the core of your training session and should take about an hour to present. However, you may want to devote additional time to some subject areas or add other subjects to be discussed, depending on the needs of the clubs. You should discuss your agenda with the lt. governor education and training to ensure your program is appropriate.

2. Obtain and Prepare Materials

- ▶ Prepare visuals using the master copies found in the appendix or on the TI Web site. If a flip chart will be used instead of computer-based visuals, prepare it in advance: Write the information on every other flip chart page, using a marking pen and making sure all letters are large enough to be clearly visible to participants. Tips for effectively using visual aids are included in Part IV.
- ▶ Duplicate the handouts and evaluation form in Part III of this program, along with any additional handouts you will distribute.
- ▶ Assemble reference materials. These may be available from the district, or you can order them through the Toastmasters International supply catalog. Be sure to allow adequate time for shipping.

3. Select Training Assistants

You may want to have someone assist you in conducting the session (distributing handouts, etc.). Select that person in advance and explain what type of help you will need.

B. THE TRAINING ENVIRONMENT

A satisfactory physical environment is essential for an effective training session. In advance, arrange for your meeting room to be set up properly. You will need a room large enough to seat the attending officers comfortably. Ideally, it should have space in the back for coffee breaks, as well as sufficient room in front to accommodate your electronic equipment and a work table for materials and supplies. Make sure you have a data projector, computer and screen if you are using computer-based visuals, and don't forget to include a spare bulb and extension cord.

The chart below illustrates an ideal physical setting for a training session.

KEY

A - lectern
and gavel

B - projector and
laptop computer

C - flip chart

D - screen

E - table for
materials
and supplies

X - participants

Y - training
assistants

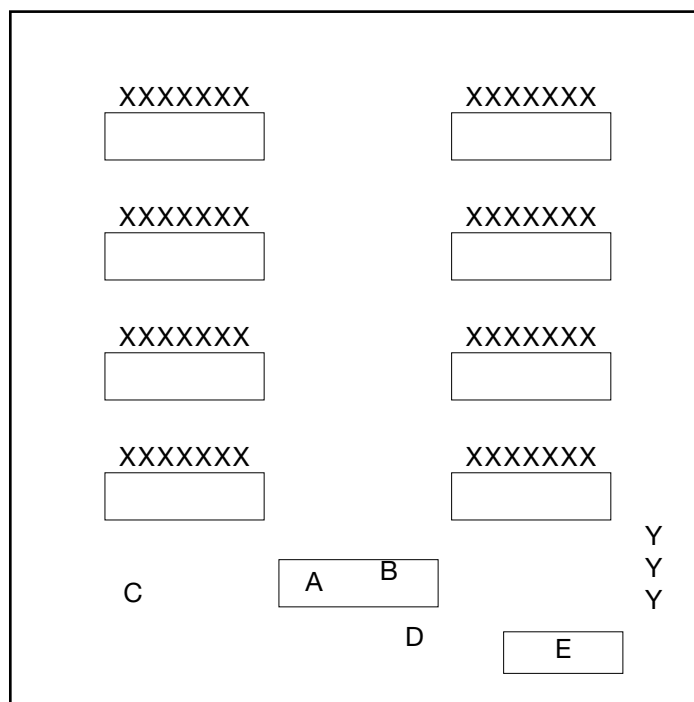

Upon arrival, check the room temperature. A room that is too hot or too cold is distracting and uncomfortable. Lastly, make it a practice to greet and chat with as many participants as possible before the session is called to order.

C. HOW TO USE THE PROGRAM OUTLINE

The training program is simple to use, but it requires considerable preparation. While designed to allow presenters the opportunity to be flexible and creative, it also provides structure and ensures the important elements are emphasized.

Notice how the training outline is structured. Interspersed throughout the outline are **boxed segments**, offering explanations and guidelines for conducting group exercises and portions of the presentation material. In the right-hand column are keys to visual aids, as well as space for your own notations.

Part II provides a training script. When presenting the material covered in Part II, do not read the outline as a script. Instead, become thoroughly familiar with each topic, then paraphrase and embellish it to suit your individual presentation style. Remember new officers may not be familiar with Toastmasters jargon and acronyms such as CC and DTM. Keep two things in mind when preparing for your training session. First, fit your planned discussion to the time allotted. Second, allow ample time for group discussion and participation. If you find you are going overtime or the program is too lengthy, do not delete entire topics; rather, address them briefly and tell participants what resources they can use to get additional information. (The officer handbooks, for example, are an excellent resource for incoming officers.)

Part III provides handouts and an evaluation form to be distributed during the session according to the script. Be sure to make sufficient copies.

Part IV of this booklet contains the basic visual aids for the program. Each is designated in the right hand column as V # ___ in the outline. PowerPoint visuals are available on the Toastmasters International Web site, or you can copy the text on a flip chart.

D. CHECKLIST FOR CLUB OFFICER TRAINING

- _____ Training assistants appointed
- _____ Visual aids prepared
- _____ Handouts reproduced
- _____ Room arranged and properly equipped
- _____ Coffee and refreshments ordered
- _____ Supplies and reference materials on hand
- _____ Projector, computer, screen, spare bulb and extension cord available
- _____ Flip chart and easel available, along with marking pens
- _____ Notepads and pencils available for each participant

E. EVALUATION AND FOLLOW-UP

- A. Session Leaders: Ask the participants to fill out the evaluation form at the end of the session. Alter your material as needed based on feedback you receive.
- B. Club Application: Evaluate trainees' use of materials. Be sure to follow-up with club leaders throughout their term. Keep in mind that learning is a continuous process.
- C. Refresher Sessions: Hold formal or informal review sessions as frequently as possible. If necessary, hold a make-up session for those who were unable to attend.



PART II: PRESENTATION OF THE TRAINING SESSION

PRESENTER: Welcome the group and present a brief opening address focusing on the importance of the club experience in the personal development of members. The comments should be positive and highly motivational in nature, emphasizing a commitment to member service in all aspects of the Toastmasters club. Also mention the length of the training, the location of the rest rooms and phones, and other pertinent information. But remember: Time is precious and must be controlled carefully throughout the session.

Serving as vice president membership is a great opportunity. You are responsible for helping more people enjoy the benefits of Toastmasters by building the club's membership. It is an exciting opportunity for you. You will learn and practice marketing and sales skills, campaign planning and public relations skills that you will be able to use in all aspects of your life.

Today we're going to discuss your role as vice president membership and how to fulfill your responsibilities. Every club officer, including you, has performance standards to be met. These standards help officers clearly understand their roles and provide a point of reference for club members to better understand what to expect from club officers, to evaluate current leaders and candidates for office, and facilitate communication when expectations differ among club officers and

members. The standards identify performance members should expect from club officers outside of each club meeting and performance they should expect from club officers at the club meeting.

In the next hour we're going to review your standards as vice president membership and discuss the steps you can follow to meet these standards. Later you'll be participating in some exercises to practice what you've learned.

Your standards outside of the club meeting are to:

HO #1

1. Conduct ongoing membership building programs and efforts.
2. Promote the membership goal of one new member per month.
3. If the club has fewer than 20 members, promote achieving 20 members by year-end or sooner.
4. Promote club and Toastmasters International membership building programs.
5. Conduct a minimum of two formal club membership programs annually.
6. Follow up on and keep track of guests, new members joining, and members not attending meetings. Telephone, send note or e-mail guests.
7. For all prospective members, explain the educational program, get their commitment to join, and collect membership applications.

8. Bring the applications to the club for voting and, if the members are accepted, collect dues and fees and give them to the treasurer with the applications.
9. Attend club executive committee meetings.
10. Attend and vote at area council meetings.
11. Attend district-sponsored club officer training.
12. Arrange for a replacement if unable to attend club meeting.
13. Prepare your successor for office.

Your standards at the club meeting are to:

1. Greet guests and have each complete a guest card.
2. Report on current membership, promote membership campaigns, and welcome new members.
3. Work with the president and vice president education to ensure each new member is formally inducted at the first meeting after being voted in by the club.
4. Help guests wishing to join complete the Application for Membership.
5. Speak with fellow members to determine if their needs are being met.

Please keep in mind it's impossible to cover every detail of your responsibilities as vice president membership today. Our goal in this session is to provide you with a

basic foundation as well as with resources available from World Headquarters and the district. Feel free to ask questions. And remember to attend other sessions. All are intended to help you be successful during your term of office.

The purpose of a Toastmasters club is to provide an environment in which members can learn communication and leadership skills. As the vice president membership of your club, you influence that environment. You serve as part of a team that consists of the president, vice president education, vice president public relations, secretary, treasurer, and sergeant at arms. Each one of you is responsible for making your club dynamic and enjoyable for all members by working together as a team and for making sure the club is recognized at least as a Distinguished Club in the Distinguished Club Program. You can accomplish this by holding regular and productive executive committee meetings and through careful goal-setting, planning, and monitoring of progress. The Distinguished Club Program recognizes clubs for achievement in education and membership growth and will be discussed in greater detail during a separate training session.

Now let's discuss some of the standards mentioned earlier.

Membership Building

Members are the backbone of the Toastmasters program. As an organization of clubs and volunteers, we exist solely to serve members and help them develop communication and leadership skills that can be gained through Toastmasters.

But since we live in a mobile society, many people find themselves having to make changes or adjustments in jobs, residences, and lifestyles. Toastmasters are not immune to these changes, and perhaps you have noticed already that some of your members find it difficult to make a strong commitment to the club.

Your club roster currently may reflect a healthy membership, but circumstances beyond your control could alter this situation within a short time. Anticipate these changes and work continuously toward increasing your membership. Even if your club is in the comfortable 40-plus category, it's important you strive to bring in new members: doing so will give your club a stronger leadership base and provide the club with a continuous flow of new ideas and personalities. For these reasons, every club should have a goal of at least one new member per month. If your club has fewer than 20 members, its goal should be to have a minimum of 20 members.

VPM-V #1

VPM-V #2

Reaching and keeping your club at charter strength is your most important job.

Before World Headquarters can issue a charter, it first must be established that the

club will number 20 or more members. Why 20 members? Experience shows that clubs have an optimum chance for success when 20 or more members are available to take on the multitude of meeting roles and speaking assignments that keep a club exciting and varied.

The same rule that applies to charter clubs applies to your own club as well.

Twenty members are necessary to support a Toastmasters program effectively.

When club membership drops below that number, the talents, abilities, and energies of those who remain are in danger of being stretched too thin.

You can build the club's membership using the following strategies:

- ▶ **Promote the benefits to current membership.** Once they join, most people are sold on Toastmasters. Still, it's always a good idea to review the benefits of being a Toastmaster with your current membership. Set aside some meeting time for each person to discuss briefly how being a Toastmaster has made a difference in his or her life; personal testimonials are a great way to get the ball rolling!

- ▶ **Promote the benefits to non-Toastmasters.** Next, encourage your fellow members to follow your lead in bringing new members to the club. To

VPM-V #3

begin with, look for extra inspiration and ideas from some of the helpful promotional brochures and booklets available through World Headquarters, including “Find Your Voice” (Catalog No. 99), “Confidence. The Voice of Leadership.” (Catalog No. 101), “Clear Communication. Your Organization Needs It.” (Catalog No. 103), “All About Toastmasters” (Catalog No. 124), and “From Prospect To Guest To Member” (Catalog No. 108).

How about some ready-made strategies? If you belong to a community club, send news releases to local publications and post fliers at libraries and medical offices. Do you belong to a company club? Try distributing fliers to every department or posting them in designated areas, and arrange to publish a regular notice in your in-house publication. Conduct a Speechcraft program for your community or company. Often Speechcraft participants will join your club after they experience its benefits.

Then there’s “word of mouth,” which is often one of the most successful strategies of all. Most people are encouraged to join Toastmasters after speaking with members who enthusiastically recommend the Toastmasters program.

- ▶ **Hold contests.** An excellent way to introduce others to the benefits of being a Toastmaster and provide fun for those who are already members is to hold membership building contests. Doing so not only benefits your membership roster, but also stimulates greater interest and involvement among your members. Your club should conduct a minimum of two formal membership programs annually.

You can create your own program. A sample program, “A Simple Membership Building Program” complete with ideas regarding recognition, promotion, and tracking, is available free of charge from World Headquarters (Catalog No. 1621).

Regardless of the time of year, there is always at least one membership building contest being run by Toastmasters International. Employ at least two of the following contests as part of your strategy for building membership:

- ❑ *Annual Membership Program* – In effect every day of the year, this program acknowledges individuals who have sponsored five, 10, 15, or more new members during the program.

- ❑ *Smedley Award* – This program commemorates the founding of Toastmasters International on October 22, 1924, by recognizing clubs which add five or more members during the months of August and September. Clubs that do so will receive an award suitable for display on their club banner.

- ❑ *Talk up Toastmasters* – This membership promotion program recognizes clubs that add five members during the months of February and March, a great time to add members to any club. The club will receive an award suitable for display on the club banner. Your district governor will be notified if your club receives this award. She/he may wish to recognize your club at the following district conference.

- ❑ *Beat the Clock!* – Your club can quickly build Distinguished Club Program credit by adding new members. In addition, when your club adds five new, dual, or reinstated members to your roster between May 1 and June 30, you also earn your choice of one item from *The Better Speaker Series* or *The Successful Club Series* modules.

Be sure to become familiar with each of these contests and their objectives. Details about them are in the Membership Programs flier (Catalog No. 1620), available from World Headquarters. Finally, when planning your contest, don't forget to keep

it lively, creative, and entertaining – such enthusiasm is contagious and a surefire way to attract new members! Report on progress during each club meeting.

To learn more about membership building and download free fliers and programs visit the Membership Building Ideas and Resources page at www.toastmasters.org.

PRESENTER: Ask participants to share what their club has done that resulted in new members joining the club.

- **Offer recognition.** Although your own efforts as an officer can go a long way in bringing in new members, former vice presidents membership agree that the individual members of each club are potentially the best promotional assets.

Recognition is an important aspect of Toastmasters achievement, and whenever current members bring in new members, it is important for them to be recognized for their efforts. Conduct *The Successful Club Series* module “Finding New Members for Your Club,” to remind everyone in your club that recruiting new Toastmasters is an ongoing responsibility for them all, then introduce some special incentives. If you would like to present those who bring in a set number of new members with an affordable gift,

the supply catalog offers a variety of attractive and useful items such as jewelry, desk accessories, and speaker aids that also incorporate the Toastmasters International logo.

Transform Guests into Members

VPM-V #4

Bringing guests to your club is a step in the right direction – but how do you transform them into members?

- ▶ **Personally welcome guests and introduce them to others.** As a conscientious Toastmaster, you've always demonstrated friendliness and hospitality toward club visitors; now, as vice president membership, continue to set that good example by greeting guests at the door. Be sure to introduce each guest to at least one other member of your club before the meeting is called to order, and invite them to sit with you or with one of the other club officers. Since it is customary for club members and officers to wear their badges or pins, visitors will feel like "one of the group" if guest badges (Catalog No. 231) are available. And don't forget to have visitors sign their names in the club's Toastmasters guest book (Catalog No. 84); aside from the favorable impression that such a book creates, the guest book provides easily accessed contact information, allowing you to follow up each guest's visit with a phone call or note.

- ▶ **Explain the benefits of becoming a Toastmaster.** After having introduced yourselves, ask your guests how they happened to visit your club and what they expect to learn or achieve in Toastmasters. Then briefly explain how your club operates and how club membership helps people become better communicators and leaders.

Invite guests to attend another meeting. If a guest indicates interest in joining, ask him or her to first complete a membership application (but do not collect dues yet).

- ▶ **Vote.** Your Toastmasters club is a private association, and club membership is by invitation. The Club Constitution specifies that prospective members be elected to membership.

HO #2

Most of the time your club will accept everyone who wants to join. However, you may encounter a situation in which someone wants to join your club whose goals, personality, and/or behaviors are not supportive or compatible with those of the club. An established voting procedure gives your club the opportunity to deny membership to such a person. Of course, denial of membership cannot be based on discrimination.

Your club can use this procedure to elect someone to membership:

1. Ask the prospective member to complete and sign an Application for Membership (Form 400). Introduce the member to the club, then excuse the applicant from the room.
 2. Tell the club that the prospective member wishes to join and ask for any discussion on the prospect's candidacy.
 3. At the end of the discussion, call for a vote by a show of hands or by secret ballot. The prospective member is elected to membership by a majority vote of the members present and voting.
 4. Tell the prospective member of the club's decision. If the decision is favorable, bring the applicant back into the meeting room and ask club members to welcome him or her.
 5. Collect international dues and fees and add the new member online or, if paying by check, mail them with the Application for Membership to World Headquarters.
- **Complete a new member application.** Only when a new member is added online or an application with dues payment is received and processed by World Headquarters is a person considered a member of

Toastmasters International. To avoid any delays in processing new members, ensure the Application for Membership (Form 400) is filled out accurately by following these steps:

- Have the new member print his or her name, mailing address, and telephone number. Keep in mind that some New Member Kits delivered within the United States are sent via United Parcel Service, which does not deliver to Post Office Boxes.
- Fill out the club and district numbers of the club; be sure to acquaint the new member with these numbers.
- Complete the “date joined” section, recording month and year only. The month listed must correspond with the prorated dues listed on the section labeled “Remittance” on the Application for Membership.
- Check the appropriate box representing the member’s status. A member can be one of the following:
 - **New:** First time joining a Toastmasters club.
 - **Reinstated:** A former member of any Toastmasters club who has a lapse in membership of at least six months.
 - **Transfer:** Currently a paid member of another Toastmasters club. Former club and district numbers must be listed in order for the member to retain continuous membership.

- **Dual:** Recognized by Toastmasters International as a full member of more than one club. Payment of International dues is still applicable.

If a new member is being sponsored by another member, list the sponsor's name and home club and district numbers. Also, new members should indicate which version of the New Member Kit – English, French, Spanish, Japanese, Chinese, or cassette – is preferred. (Cassettes are only for the visually impaired.)

Anyone who joins for the first time is required to pay the \$20 New Member Fee (California clubs add sales tax). The same is true for reinstated members requiring the educational materials included in the New Member Kits. Transfer members and dual members, however, are not required to pay this fee.

Dues are prorated to \$4.50 per month, based on the April and October periods. Therefore, a member who joins the club in April will pay the full \$27 dues, but a member who joins in September must only pay \$4.50 dues with the \$27 semiannual dues required the following month. Only transfer members whose dues are paid in another Toastmasters club are exempt from submitting dues with the Application for Membership. Add the total

remittance required (New Member Fee plus dues). You can sign up new members online and pay this transaction by credit card. MasterCard, VISA, Discover and AMEX are accepted for new member payments, renewal payments, and product orders. Both the applicant and a club officer must sign the application. If paying by check, send that amount to Toastmasters International in United States currency.

Make at least two copies of the application (one for the new member, one for the club file), and, if paying by check, submit the original application to Toastmasters International along with the appropriate payment. If paying by credit card, enter the information online and keep the original application in the club's permanent file. The New Member Kit (if required) will be sent directly to the new member within 48 hours of receipt of the application at World Headquarters. Remember, adding new members online will expedite the shipment of the New Member Kit to your new members.

Every day, World Headquarters receives phone calls and letters asking why a new member hasn't yet received the New Member Kit or *The Toastmaster* magazine. Usually this occurs for one of two reasons: either the application was filled out inaccurately, or World Headquarters never received the

application. After the application is completed, check the form carefully for mistakes. To expedite processing, add your new members online.

- **Welcome new members into the club.** To help the new member feel welcome, Toastmasters International strongly recommends that the club use the New Member Orientation Kit for clubs (Catalog No. 1162). A number of useful materials are provided in this kit, including an Induction Ceremony Script and an explanation of how to orient new members. This information will help the new member establish the base needed to become fully integrated into the club's educational and social structure.

Although the induction ceremony is the specific responsibility of the vice president membership, it may be performed by the club president, the vice president education, or by any senior Toastmaster who can handle the ceremony with style.

***PRESENTER:** Ask participants to share what their clubs do to induct new members*

Once the new member has joined, remind the vice president education to assign a mentor. Mentors are invaluable in helping new members become familiar and comfortable with the club and the educational program.

Guarantee Member Satisfaction

As a club officer, it is your responsibility to make sure all members are satisfied with what they are getting out of the Toastmasters club. And, as vice president membership, it is your particular concern to guarantee member satisfaction.

Contact members who have missed one meeting or more. Tell them how much they are missed and encourage them to attend the next meeting. The member may have business or family concerns which prevented attendance and are beyond the club's control. Occasionally, however, a member stops attending because he or she received an especially critical evaluation or is otherwise unhappy with club meetings or other club-related matters. Do your best to determine the reason and do what you can to resolve the matter.

A way to monitor all members' satisfaction is to use the Member Interest Survey (Catalog No. 403) and New Member Profile Sheet (Catalog No. 405) to discover what members enjoy about Toastmasters, what – if anything – they are dissatisfied with, and what can be done to help hold their interest in the Toastmasters program.

You also may monitor member satisfaction effectively by periodically distributing evaluation forms called Club Climate Questionnaires (Catalog No. 251C) to your members. This helpful tool can provide insight to the members' thoughts and

feelings about the club. After evaluating the gathered data, identify ways to improve the club meeting. Whatever you do, always encourage members to remain active in the club by reviewing the social and educational benefits of Toastmasters.

Dues Renewal. Twice each year, in October and April, your club is required to send World Headquarters dues along with the names of members for whom dues are being paid. The roster is based on an invoice World Headquarters sends to your club president.

One of your responsibilities is to work with the president, treasurer and secretary in verifying the names and addresses on the list and then to make any necessary corrections. Do not add the names and addresses of any new members who joined **after** the start of the dues period (October 1 or April 1); instead, add new members online or if paying by check, send a membership application for each new member to World Headquarters in a separate envelope.

Double check your work. An accurate dues renewal is important, and accidentally omitting someone from your list not only jeopardizes that person's eligibility for speech contests and educational awards but also removes their name from the subscription list of *The Toastmaster* magazine. Also be wary about sending in dues for people who have not paid the club. Don't assume these people will renew;

if they don't, your club loses money. Once your club has submitted its renewals, you can pay for additional members as they pay you. A list of unpaid members will appear on the screen if you pay for them online.

World Headquarters sends the Dues Renewal Invoice to your club's president in early September and early March, and payment is due October 1 and April 1.

At the latest, it must be received by World Headquarters on or before 5 p.m. PT October 10 and April 10 respectively. Be sure to keep a copy for your club's records.

Whenever possible, submit your dues payment online. You will receive confirmation of receipt. Remember, your club receives credit in the Distinguished Club Program when the above deadlines are met.

- ▶ **Attend and vote at area council meetings.** As vice president membership, you also are a member of the area council. This council serves as your club's link to the district, so it is important that you represent your club members by attending council meetings, voting on the issues that affect them, and then reporting back any necessary or relevant information to the others at your next club meeting.

- ▶ **Arrange for a replacement.** Occasionally you may not be able to attend a club meeting or you know you will be late. In these cases, arrange for

someone to handle your responsibilities for you. This will help the club to function smoothly.

As you participate in the vice president membership activities that we have just discussed, take notes and think of how you will prepare the person who will succeed you. It is essential that you forward all necessary materials and records to your successor, but don't let it stop there; offer to assist the new officer as he or she is learning the duties of vice president membership.

HO #3

PRESENTER: This handout is a list of resources for the officers. It includes prices and an order form.

PRESENTER: Continue with one or both of the following case studies. The participant section of each case study is located in Part III for copy and distribution. Afterward, if you have time, answer questions and perhaps give a short motivational closing.

CASE #1

*Case Study for Vice Presidents Membership:
Membership Retention*

Objective: To find ways to encourage members to remain active from one semiannual period to the next.

Time: 15 minutes

Process:

1. Distribute copies of the case study sheet in Part III to the training session participants.
2. Divide participants into groups of three.
3. Have each group brainstorm three effective ways to encourage members to remain active.
4. Record on a flip chart one idea from each group.

Recommended Solutions:

- Club members will be more likely to stay when the club has an interesting and varied club program, a friendly atmosphere, opportunities for involvement, recognition of member achievement, and enthusiastic leadership. Show interest in the members and they will want to remain in the club.
- Have your vice president education conduct a Member Interest Survey (Catalog No. 403). This is beneficial to all members since the surveys will help you determine your members' needs so you can incorporate them into club programming.

HO #4

CASE #2

*Case Study for Vice Presidents Membership:**How to Handle Guest Visits*

Objective: *List appropriate behaviors members should display when a guest is visiting your club.*

Time: *15 minutes*

Process:

- 1. Distribute the case study sheet in Part III.*
- 2. Ask the participants to diagnose the case to arrive at solutions.*
- 3. Ask the group as a whole how they would resolve the issue and write several of the suggestions on a flip chart.*

HO #5

Recommended Solutions:

- If time permits, greet guests with a friendly smile at the door. Ask about their background and why they chose to visit your club. Then explain how the club operates and how membership in your club can help them.*
- Make guests feel welcome by letting them know they don't have to participate in the meeting, although they will be introduced to the club and are welcome to share information about themselves at that time.*
- If you have not had the chance to greet a guest personally prior to the meeting, be sure to have them recognized at some point during the meeting. If the guest arrived with a member, ask that member to introduce the guest to the rest of the club.*
- Encourage guests to visit again; be sure to follow up with a phone call or note.*



PART III: HANDOUTS

The following handouts may be reproduced for distribution to your training session participants. Make certain you accurately project the number of attendees so you have enough.

Feel free to revise the material to suit your own style.

VICE PRESIDENT MEMBERSHIP STANDARDS

Outside of the club meeting...

1. Conduct ongoing membership building programs and efforts.
2. Promote the membership goal of one new member per month.
3. If the club has fewer than 20 members, promote achieving 20 members by year-end or sooner.
4. Promote club and Toastmasters International membership building programs.
5. Conduct a minimum of two formal club membership programs annually.
6. Follow up on and keep track of guests, new members joining, and members not attending meetings. Telephone, send note, or e-mail guests.
7. For all prospective members, explain the educational program, get their commitment to join, and collect membership applications.
8. Bring the applications to the club for voting and, if the members are accepted, collect dues and fees and give them to the treasurer with the applications.
9. Attend club executive committee meetings.
10. Attend and vote at area council meetings.
11. Attend district-sponsored club officer training.
12. Arrange for a replacement if unable to attend club meeting.
13. Prepare your successor for office.

At the club meeting...

1. Greet guests and have each complete a guest card.
2. Report on current membership, promote membership campaigns, and welcome new members.
3. Work with the president and vice president education to ensure each new member is formally inducted at the first meeting after being voted in by the club.

PROCEDURE FOR VOTING IN MEMBERS

Your Toastmasters club is a private association, and club membership is by invitation. The Club Constitution specifies that prospective members be elected to membership. Voting in members is not an option, it is a requirement.

Most of the time your club will accept everyone who wants to join. However, you may encounter a situation in which someone wants to join your club whose goals, personality, and/or behaviors are not supportive or compatible with those of the club. An established voting procedure gives your club the opportunity to deny membership to such a person. Of course, denial of membership cannot be based on discrimination.

Your club can use this procedure to elect someone to membership:

1. Ask the prospective member to complete and sign an Application for Membership (Form 400). Introduce the member to the club, then excuse the applicant and guests from the room.
2. Tell the club that the prospective member wishes to join and ask for any discussion on the prospect's candidacy.
3. At the end of the discussion, call for a vote by a show of hands or by secret ballot. The prospective member is elected to membership by a majority vote of the members present and voting.
4. Tell the prospective member of the club's decision. If the decision is favorable, bring the applicant back into the meeting room and ask club members to welcome him or her. If the vote is not favorable, a group of officers should advise the applicant of the club's decision.
5. Collect International dues and fees and either add the new member online or mail the dues and fees with the Application for Membership to World Headquarters.

Many clubs have conducted this procedure at the end of the meeting, rather than at the beginning.



Toastmasters Membership Application

CLUBS WITHIN DISTRICTS

For faster service,
add and pay your
new members online

Club Number:

District Number:

Month / Year Joined: /

Club Name: _____ City: _____

Membership Type:

- New
- Reinstated (break in membership)
- Renewing (no break in membership)
- Dual
- Transfer from club Number / Name

Member # (if known)

LAST NAME / SURNAME / FAMILY NAME:

FIRST NAME / GIVEN NAME:

MIDDLE INITIAL / NAME:

OTHER ADDRESS INFO (FLOOR NUMBER, BUILDING NUMBER, MAIL STOP):

ADDRESS LINE 1 (APARTMENT OR SUITE NUMBER):

ADDRESS LINE 2 (HOUSE / BUILDING NUMBER, STREET NAME):

CITY:

STATE / PROVINCE:

- MALE
- FEMALE

COUNTRY:

ZIP / POSTAL CODE:

HOME PHONE NUMBER:

CELL PHONE NUMBER:

WORK PHONE NUMBER:

FAX NUMBER:

E-MAIL: _____

New Member Kit preference for new members only:

- English
- Chinese (Mandarin)
- French
- Cassette tape
(visually impaired only)
- Spanish
- Japanese

Please do not send promotions to me from Toastmasters International's partners.

NEW/REINSTATED/DUAL MEMBER SPONSOR: The person who recruited and/or encouraged the member to join.

NOTE: TO ENSURE PROPER CREDIT, THE SPONSOR'S FULL FIRST AND LAST NAME AND HOME CLUB NUMBER MUST APPEAR.

LAST NAME / SURNAME / FAMILY NAME:

FIRST NAME / GIVEN NAME:

MIDDLE INITIAL / NAME:

SPONSOR'S DISTRICT NUMBER:

SPONSOR'S HOME CLUB NUMBER:

MEMBER NUMBER (if known)

PLEASE READ AND COMPLETE THE OTHER SIDE

1. NEW MEMBER FEE U.S. \$20.00 \$ _____
Paid only by new members. Covers costs of the New Member Kit and processing.
- 1a. California clubs add 7.75% sales tax (\$1.55) \$ _____
2. Membership Dues (all members)
Pro-rated at \$4.50 per month. Month chosen must match "month/year joined" listed on previous page.
- | | | | | |
|-----------------------------------|----|------------------------------------|--------------|----------|
| <input type="checkbox"/> October | or | <input type="checkbox"/> April | U.S. \$27.00 | \$ _____ |
| <input type="checkbox"/> November | or | <input type="checkbox"/> May | 22.50 | _____ |
| <input type="checkbox"/> December | or | <input type="checkbox"/> June | 18.00 | _____ |
| <input type="checkbox"/> January | or | <input type="checkbox"/> July | 13.50 | _____ |
| <input type="checkbox"/> February | or | <input type="checkbox"/> August | 9.00 | _____ |
| <input type="checkbox"/> March | or | <input type="checkbox"/> September | 4.50 | _____ |
3. Total of 1, 1a, and 2 \$ _____

CLUB DUES WORKSHEET FOR CLUB USE ONLY	
International fees and dues: (from Line 3 on left)	\$ _____
Club New Member Fee:	_____
Club Dues:	_____
Total:	\$ _____

By my signature below, I agree to the terms of *A Toastmaster's Promise*, and the *Indemnification and Release* stated below, and certify that I am 18 years of age or older, in compliance with the Toastmasters International Club Constitution.

PAYMENT INFORMATION Choose one:

- Check: No. _____ Amount \$ _____
- Credit Card: MC Visa American Express Discover
- Card No. _____ Exp. Date _____
- Signature / Name on Card _____
- Other _____

SIGNED: _____
APPLICANT

By my signature below, I certify that this individual has joined the Toastmasters club identified above. As a club, we will ensure that this member receives proper orientation and mentoring.

Check or money order in US funds drawn on a US bank, or credit card payment, must be included. Line 3 is the amount payable to Toastmasters International.

NOTE: Your club may also charge dues to meet club expenses. Unfortunately, WHQ is unable to charge club dues on the credit card submitted. Club dues must be paid directly to the club. See second column for details. **Dues and fees are payable in advance and are not refundable or transferable.**

SIGNED: _____
CLUB OFFICER

MEMBER'S AGREEMENT AND RELEASE:

Consistent with my desire to take personal responsibility for my conduct, individually and as a member of a Toastmasters club, I agree to abide by the principles contained in "A Toastmaster's Promise" and the governing documents and policies of Toastmasters International and my club. I will refrain from any form of discrimination, harassment, derogatory, illegal, or unethical conduct, and I understand that if I engage in such conduct, I may be responsible to reimburse Toastmasters International, my club or other clubs, or other individuals involved with Toastmasters, for any damages, losses, or costs resulting from my conduct. Understanding that Toastmasters programs are conducted by volunteers who cannot be effectively screened or supervised by Toastmasters International or its clubs, I release and discharge Toastmasters International, its clubs, governing bodies, and representatives from any liability for the intentional or negligent acts or omissions of any member or officer of my club or other clubs, or any officer of Toastmasters International.

A TOASTMASTER'S PROMISE

As a member of Toastmasters International and my club, I promise ...

- ◆ To attend club meetings regularly;
- ◆ To prepare all of my speeches to the best of my ability, basing them on projects in the Communication and Leadership Program manual or the Advanced Communication and Leadership Program manuals;
- ◆ To prepare for and fulfill meeting assignments;
- ◆ To provide fellow members with helpful, constructive evaluations;
- ◆ To help the club maintain the positive, friendly environment necessary for all members to learn and grow;
- ◆ To serve my club as an officer when called upon to do so;
- ◆ To treat my fellow club members and our guests with respect and courtesy;
- ◆ To bring guests to club meetings so they can see the benefits Toastmasters membership offers;
- ◆ To adhere to the guidelines and rules for all Toastmasters educational and recognition programs;
- ◆ To maintain honest and highly ethical standards during the conduct of all Toastmasters activities.

CLUB OFFICER – Please keep a copy for your club's records. If paying online, go to www.toastmasters.org, club business. If mailing, send to: Membership Records, Toastmasters International, P.O. Box 9052, Mission Viejo, CA 92690 USA. If faxing, send to: 949-858-1207. **NOTE:** Please submit information via one method only to avoid duplication. For fastest results, enter new members online.

RESOURCES LIST

Achieving Success as Vice President Membership

Following are some materials you may want to order to ensure a successful term as vice president membership:

Quantity			Total	
_____	1205	Supply Catalog	\$1.00	\$ _____
_____	84	Guest Book	\$8.95	\$ _____
_____	99	Find Your Voice. First 20 no charge – each additional	\$.20	\$ _____
_____	101	Confidence. The Voice of Leadership. First 20 no charge – each additional	\$.20	\$ _____
_____	103	Clear Communication. Your Organization Needs It.	\$.50	\$ _____
_____	108	From Prospect, To Guest, To Member... Prospecting for and signing new members 3 no charge—each additional	\$.25	\$ _____
_____	114	Toastmasters Can Help...Flyer promotes how to gain confidence through membership (50 each)	\$2.50	\$ _____
_____	115	Toastmasters – It's More Than Just Talk...Flyer promotes getting ahead on the job (50 each)	\$2.50	\$ _____
_____	121	How To Build A Toastmasters Club...Everything you need to know about building a new club in eight weeks	\$2.00	\$ _____
_____	124	All About Toastmasters	\$.25	\$ _____
_____	205	Speechcraft	\$20.00	\$ _____
_____	231	Guest Badge/Visitor's Card	\$3.50	\$ _____
_____	251C	Club Climate Questionnaire	\$1.50	\$ _____
_____	291	Finding New Members For Your Club	\$4.50	\$ _____
_____	292	Closing the Sale	\$4.50	\$ _____
_____	344	Guest Invitation Card (25 cards and envelopes)	\$5.25	\$ _____
_____	348	Invitation to Membership (25 cards and envelopes)	\$5.25	\$ _____
_____	354	Your Membership Provides...1-page flyer Set of 25 no charge—each additional set	\$1.25	\$ _____
_____	367	Promotional Poster...poster used in conjunction with promotional pamphlets (Set of 5)	\$4.00	\$ _____
_____	400	Application for Membership (Pad of 20)	N/C	\$ _____
_____	403	Member Interest Survey...Can be used in helping to plan club programs around needs and interest of members (Pad of 25)	\$1.50	\$ _____
_____	405	New Member Profile Sheet...Outline for introducing new members to Toastmasters and determining their goals and how to meet them (Set of 10)	\$1.00	\$ _____
_____	904	Visitor's Card...Handy information card for club guests to complete (30 each)	\$2.25	\$ _____
_____	912	Meeting Reminder Cards (Set of 20)	\$2.75	\$ _____
_____	930	Correspondence Card...Blank postcard with TI insignia (100 each)	\$3.00	\$ _____
_____	1020	Community Contact Team booklet...Explains how to organize and conduct 30-minute Toastmasters program for business, community and government groups 3 no charge—additional copies	\$.25	\$ _____
_____	1111	Distinguished Club Program/Club Success Plan	\$1.25	\$ _____
_____	1158	How To Rebuild a Toastmasters Club..Guidelines for reviving a struggling club.	\$1.00	\$ _____

_____	1159	Membership Growth Manual... An array of ideas for attracting new members	\$2.25	\$ _____
_____	1160	Membership Building Kit... Collection of promotional brochures and booklets in a handsome folder	\$5.00	\$ _____
_____	1162	New Member Orientation Kit For Clubs... Folder containing everything your club needs to orient and induct new members	\$5.50	\$ _____
_____	1167	Toastmasters and You... For new members before they receive New Member Kit from WHQ	\$2.50	\$ _____
_____	1167A	Package of five "Toastmasters and You" Kits	\$12.00	\$ _____
_____	1310C	Vice President Membership Handbook	\$2.50	\$ _____
_____	1325	New Member Record Sheet... Records all vital information for new members from date of joining until induction	\$.25	\$ _____
_____	1326	Member Sponsorship Progress Chart... For monitoring performance in membership awards programs	\$.25	\$ _____
_____	1327	Prospective Member Follow-Up... Useful chart for following up guests' visits (10 each)	\$1.75	\$ _____
_____	1620	Membership Programs flier... Explains current annual membership building program and awards (3 per club)	N/C	\$ _____
_____	1621	A Simple Membership Building Program... Easy to follow guidelines for conducting a membership building program in your club	N/C	\$ _____

TOTAL \$ _____

CA clubs add 7.75% \$ _____

TOTAL AMOUNT \$ _____

Mail to: Toastmasters International; P.O. Box 9052,
Mission Viejo, CA 92690 U.S.A.
or telephone (949) 858-8255 Fax No. (949) 858-1207

PAYMENT MUST ACCOMPANY ORDER

___ Enclosed is my check in the amount of \$ _____ (U.S.) or

___ Please bill against my MasterCard / VISA / AMEX / Discover (Circle one)

Credit Card No. _____ Expiration Date _____

Signature _____

Name _____

Club No. _____ Club Name _____

Address _____

City _____ State/Province _____

Country _____ Postal Code _____

Email _____ Phone Number _____

Standard Domestic Shipping Prices - 2006					
TOTAL ORDER		SHIPPING CHARGES	TOTAL ORDER		SHIPPING CHARGES
\$0.00 to	\$2.50	\$1.80	35.01 to	50.00	\$7.90
2.51 to	5.00	3.45	50.01 to	100.00	9.15
5.01 to	10.00	4.15	100.01 to	150.00	12.15
10.01 to	20.00	4.90	150.01 to	200.00	15.15
20.01 to	35.00	6.90	200.01 to	—	Add 10% of total price

For orders shipped outside the United States, see the current Supply Catalog for item weight and shipping charts to calculate the exact postage. Or, estimate airmail at 35% of order total, though actual charges may vary significantly. Excess charges will be billed. All prices subject to change without notice.

Order online at www.toastmasters.org

CASE STUDY #1

CASE STUDY FOR VICE PRESIDENTS MEMBERSHIP: RETAINING MEMBERS

You notice that the members who were inducted at the same time you were inducted are no longer coming to club meetings as often as they used to. They have either completed their CCs, or they have lost interest in the club.

As vice president membership, how would you encourage members to remain active?

CASE STUDY #2

CASE STUDY FOR VICE PRESIDENTS MEMBERSHIP: HOW TO HANDLE A GUEST VISIT

Another meeting has just ended. Two members brought guests with them, but since they all arrived just before the meeting was called to order, you haven't had a chance to speak with them until this moment. You approach the guests, introduce yourself and ask them what they thought of the meeting.

"It was very interesting," answers the first guest. The other nods her head in agreement, then adds, "It was nice meeting you" – and moves toward the door. The other guest follows.

What could you have done differently to encourage these guests to join your club?

EVALUATION FORM

Date: _____ Program Name: _____

Facilitator: _____

On a scale of one to five, five being the highest rating, please rate the course and facilitator on the following items by circling the number you find most appropriate:

1. How relevant was this session to your job in Toastmasters?
1 2 3 4 5

2. Rate the following:
Course content 1 2 3 4 5
Course material 1 2 3 4 5
Facilitator 1 2 3 4 5
Activities/exercises 1 2 3 4 5

3. Were the objectives clearly stated?
1 2 3 4 5

4. How was the lesson plan organized?
1 2 3 4 5

5. Did the instructional methods clearly illustrate the instructor's plan?
1 2 3 4 5

6. To what extent did the visual aids add to your understanding of the presentation?
1 2 3 4 5

7. How were the meeting facilities?
1 2 3 4 5

8. What are two things you learned that will make you a more effective club officer?

Additional Comments:

PART IV:

VISUAL AIDS COPY FOR THE TRAINING SESSION

Materials on the following pages are designed specifically for the presenter to use in conducting the training session. You can reproduce them as transparencies for use on an overhead projector, or handwrite them on a flip chart. PowerPoint slides are available for downloading from the TI Web site if you will be using a laptop computer, data projector and screen.

In the right-hand column are keys for visual aids. Their placement indicates the points at which they should be displayed. Each is numbered. For example, **VPM-V #1** stands for “the first visual.” You also may use the right-hand margin for making notes.

TIPS ON USE:

1. **Show the visual aid only while you are talking about it.**
2. **Be sure everyone in the audience can see the visuals clearly.** Visibility to the people at the rear of the room is your guide.
3. **Talk to the audience, not to the visual.** Maintain eye contact even when your listeners are looking at the visual. This will help you judge their understanding.
4. **Don't overdo it.** You need not illustrate every point in the speech.
5. **Rehearse.** Nothing is more important than adequate preparation. Know how and when you will use the visual, and practice so you will make a smooth presentation. Anticipate all possible problems, especially when electronic equipment is involved.
6. **Remember . . .** Be as professional as possible.

Membership Goals

- Every club should add at least one new member per month.

- If your club has fewer than 20 members, its goal should be to have a minimum of 20 members by year-end.

Strategies for Membership Growth

- Promote growth benefits to current membership
- Promote Toastmasters benefits to others
- Hold at least two membership contests
- Offer recognition

Transform Guests Into Members

- Personally welcome guests and introduce them to others
- Explain benefits
- Vote
- Complete application / submit online
- Welcome new members into the club

Guarantee Member Satisfaction

- Contact absent members
- Conduct surveys
- Distribute evaluation forms