

Achieving Success as Treasurer

Club Leadership TRAINING PROGRAM



TOASTMASTERS
INTERNATIONAL

THE MISSION OF THE CLUB

The mission of a Toastmasters club is to provide a mutually supportive and positive learning environment in which every member has the opportunity to develop communication and leadership skills, which in turn foster self-confidence and personal growth.



©Toastmasters International®
P.O. Box 9052
Mission Viejo, California 92690 U.S.A.
(949) 858-8255
www.toastmasters.org

TRAINING CLUB LEADERS . . . A VITAL FUNCTION

As a coordinator for Club Leadership Training, you have one of the most important roles in Toastmasters.

The quality of a club meeting determines whether people join and stay in our organization. For a Toastmasters club, success lies in the ability to provide an environment that fosters meaningful self-development for all members. This is where officer training comes into play. Club officers must know their roles and responsibilities. The trainer's job is to explain this and make sure all officers understand why their roles are so important for the overall success of the club. Your effectiveness as a trainer can make the difference between success and failure for a Toastmasters club.

Preparation is the cornerstone of a good training session. Take time to review the handbook, then study the training program thoroughly. Don't forget to inject your own personality and experiences to create a session that is educational, enjoyable, and motivational. Helpful tips to assist in your preparation for this training session are provided in Part I. Part II covers the essential points of the session while Part III provides you with handouts to distribute. Part IV contains copy for your visual aids. **This entire training program, including PowerPoint slides, is available for downloading on the Toastmasters International Web site, www.toastmasters.org.**

This program is your comprehensive guide for preparing and presenting an effective club officer training session for the office of treasurer. By the end of the session, the members of your audience will be familiar with such basic competencies as preparing an annual budget, providing the bank with a new signature card, notifying members of dues payable, collecting payable dues and fees, issuing checks for semiannual membership dues and new member fees, paying all bills promptly, keeping records of all financial transactions, presenting financial reports, submitting their club accounts for audit, responding to inquiries, and preparing their successor for office.

TABLE OF CONTENTS SECTION

CONTENT	PAGE
PART I	PREPARING FOR THE TRAINING SESSION
A. Three Steps in Planning a Successful Training Program	4
B. The Training Environment	5
C. How to Use the Program Outline	6
D. Checklist for Club Officer Training	7
E. Evaluation and Follow-Up	7
PART II	PRESENTATION OF THE TRAINING SESSION
Script	8
PART III	COPIES OF HANDOUTS AND EVALUATION FORM
PART IV	VISUAL AIDS COPY FOR THE TRAINING SESSION

PART I: PREPARING FOR THE TRAINING SESSION

A. THREE STEPS IN PLANNING A SUCCESSFUL TRAINING PROGRAM

1. Prepare the Training Agenda

The information in this manual should be the core of your training session and should take about an hour to present. However, you may want to devote additional time to some subject areas or add other subjects to be discussed, depending on the needs of the clubs. You should discuss your agenda with the lt. governor education and training to ensure your program is appropriate.

2. Obtain and Prepare Materials

- ▶ Prepare visuals using the master copies found in Part IV or on the Web site. If a flip chart will be used instead of computer-based visuals, prepare it in advance: Write the information on every other flip chart page, using a marking pen and making sure all letters are large enough to be clearly visible to participants. Tips for effectively using visual aids are also included.
- ▶ Duplicate the handouts and evaluation form in Part III of this program, along with any additional handouts you will distribute.
- ▶ Assemble reference materials. These may be available from the district, or you can order them through the Toastmasters International supply catalog. Be sure to allow adequate time for shipping.

3. Select Training Assistants

You may want to have someone assist you in conducting the session (distributing handouts, etc.). Select that person in advance and explain what type of help you will need.

B. THE TRAINING ENVIRONMENT

A satisfactory physical environment is essential for an effective training session. In advance, arrange for your meeting room to be set up properly. You will need a room large enough to seat the attending officers comfortably. Ideally, it should have space in the back for coffee breaks, as well as sufficient room in front to accommodate any electronic equipment and a work table for materials and supplies. Make sure you have a projector, computer and screen if you are using computer-based visuals, and don't forget to include a spare bulb and extension cord.

The chart below illustrates an ideal physical setting for a training session.

KEY

A - lectern
and gavel

B - projector and
laptop computer

C - flip chart

D - screen

E - table for
materials
and supplies

X - participants

Y - training
assistants

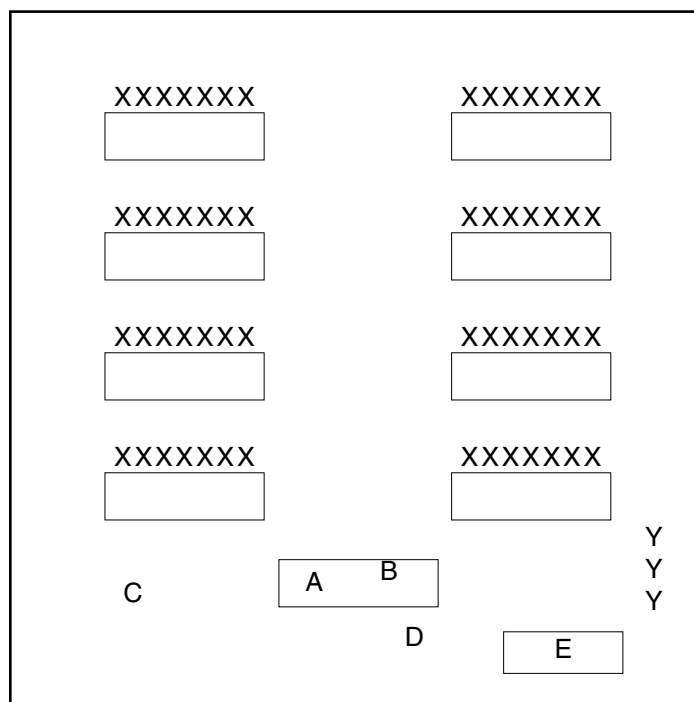

Upon arrival, check the room temperature. A room that is too hot or too cold is distracting and uncomfortable. Lastly, make it a practice to greet and chat with as many participants as possible before the session is called to order.

C. HOW TO USE THE PROGRAM OUTLINE

The training program is simple to use, but it requires considerable preparation. While designed to allow presenters the opportunity to be flexible and creative, it also provides structure and ensures the important elements are emphasized.

Notice how the training outline is structured. Interspersed throughout the outline are **boxed segments**, offering explanations and guidelines for conducting group exercises and portions of the presentation material. In the right-hand column are keys to visual aids, as well as space for your own notations.

Part II provides a training script. When presenting the material covered in Part II, do not read the outline as a script. Instead, become thoroughly familiar with each topic, then paraphrase and embellish it to suit your individual presentation style. Remember new officers may not be familiar with Toastmasters jargon and acronyms such as CC and DTM. Keep two things in mind when preparing for your training session. First, fit your planned discussion to the time allotted. Second, allow ample time for group discussion and participation. If you find you are going overtime or the program is too lengthy, do not delete entire topics; rather, address them briefly and tell participants what resources they can use to get additional information. (The officer handbooks, for example, are an excellent resource for incoming officers.)

Part III provides handouts and an evaluation form to be distributed during the session according to the script. Be sure to make sufficient copies.

Part IV of this booklet contains the basic visual aids for the program. Each is designated in the right hand column as V # ___ in the outline. PowerPoint visuals are available on the Toastmasters International Web site, or you can copy the text on a flip chart.

D. CHECKLIST FOR CLUB OFFICER TRAINING

- _____ Training assistants appointed
- _____ Visual aids prepared
- _____ Handouts reproduced
- _____ Room arranged and properly equipped
- _____ Coffee and refreshments ordered
- _____ Supplies and reference materials on hand
- _____ Projector, computer, screen, spare bulb, and extension cord available
- _____ Flip chart and easel available, along with marking pens
- _____ Notepads and pencils available for each participant

E. EVALUATION AND FOLLOW-UP

- A. Session Leaders: Ask the participants to fill out the evaluation form at the end of the session. Alter your material as needed based on feedback you receive.
- B. Club Application: Evaluate trainees' use of materials. Be sure to follow-up with club leaders throughout their term. Keep in mind that learning is a continuous process.
- C. Refresher Sessions: Hold formal or informal review sessions as frequently as possible. If necessary, hold a make-up session for those who were unable to attend.



PART II: PRESENTATION OF THE TRAINING SESSION

PRESENTER: Welcome the group and present a brief opening address focusing on the importance of the club experience in the personal development of members. Comments should be positive and highly motivational in nature, emphasizing a commitment to member service in all aspects of the Toastmasters club. Also mention the length of the training, the location of the rest rooms and phones, and other pertinent information. But remember: Time is precious and must be controlled carefully throughout the session.

Serving as treasurer is a great opportunity. You are responsible for keeping clear and accurate financial records and for seeing that the club remains financially stable. You will learn and practice budgeting and money management skills that you can use in all aspects of your life.

Today we're going to discuss your role as treasurer and how to fulfill your responsibilities. Every club officer, including you, has performance standards to be met. These standards help officers clearly understand their roles and provide a point of reference for club members to better understand what to expect from club officers, to evaluate current leaders and candidates for office, and facilitate communication when expectations differ among club officers and members. The standards identify

performance members should expect from club officers outside of each club meeting and performance they should expect from club officers at the club meeting. In the next hour we're going to review your standards as treasurer and discuss the steps you can follow to meet these standards. Later you'll be participating in some exercises to practice what you've learned.

Your standards outside of the club meeting are to:

1. Prepare a budget to be approved by the executive committee and membership within one month of taking office. T-V #1
2. Provide the bank with a new signature card by July 1/January 1. Apply for a debit card to use for club transactions online.
3. Prepare and send dues statements by August 15/February 15.
4. Collect and submit dues online to World Headquarters by October 1 and April 1, and work with the vice president membership to contact members who have not paid dues.
5. Apply online or submit new member applications and dues to World Headquarters within 48 hours after receipt.
6. Pay bills as due. T-V #2
7. Keep records of all financial transactions.
8. Present verbal and written financial reports monthly.
9. Submit club accounts for audit.

10. Attend club executive committee meetings.
11. Attend district-sponsored club officer training.
12. Arrange for a replacement if unable to attend meeting.
13. Prepare successor for office.

Your standards at the club meeting are to:

1. Receive completed new member applications and dues.
2. Announce when dues are due and explain dues structure.
3. Greet members and guests.

Please keep in mind it's impossible to cover every detail of your responsibilities as treasurer today. Our goal in this session is to provide you with a basic foundation as well as with resources available from World Headquarters and the district. Feel free to ask questions. And remember to attend other sessions. All are intended to help you be successful during your term of office.

The purpose of a Toastmasters club is to provide an environment in which members can learn communication and leadership skills. As the treasurer of your club, you influence that environment. You serve as part of a team that consists of the president, vice president education, vice president membership, vice president

public relations, secretary, and sergeant at arms. Each one of you is responsible for making your club dynamic and enjoyable for all members by working together as a team and for making sure the club is recognized as a Distinguished Club in the Distinguished Club Program. You can accomplish this by holding regular and productive executive committee meetings; through careful goal-setting, planning, and monitoring of progress. The Distinguished Club Program recognizes clubs for achievement in education and membership growth and will be discussed in greater detail during a separate training session.

Standards Outside of the Club Meeting

Now let's discuss the standards mentioned earlier. As treasurer of your club, you will:

Prepare a budget to be approved by the executive committee and membership within one month of taking office. Many people visibly deflate when the word "budget" is mentioned. Having to consider a financial plan seems to drain the fun out of any project. But savvy people understand such a plan allows for fun. And once it's in place, your budget will be the basis for financial stability that will permit your club to achieve its mission.

T-V #1

Consider income and expenses against the club's goals. As soon as possible, work with the president and executive committee to develop a budget for the upcoming

club year. Be sure to balance your club's income and expenses against what you hope to accomplish. Typical club budget expenses include trophies and ribbons, administrative supplies, educational material such as manuals, and *The Better Speaker Series*, *The Successful Club Series* and *The Leadership Excellence Series* programs. Typical incomes of a club budget include member dues and fund-raising activities.

As treasurer, you should be aware of Toastmasters' policy on fund-raising.

From time to time, clubs may conduct fund-raising activities to offset costs for educational sessions and to raise funds to further the purpose of Toastmasters International. While organizations such as Lions, Kiwanis, and Rotary focus on raising funds for community or charitable causes, Toastmasters International is an educational rather than a service organization, and all activities organized in connection with the Toastmasters name must fall within certain guidelines.

Before starting on a fund-raising project, ask yourself the following questions:

1. Is the product or service rendered by individual members donated or voluntary?

2. Is it the club, rather than individual members, that is receiving monetary compensation?
3. Is at least one-third of the club's total financial support from member dues?
4. Will the profits be used for the furtherance of Toastmasters International's tax-exempt purpose?

Any "no" answer indicates you are not operating within the policies of Toastmasters International and the fund-raising activity therefore is prohibited.

As just mentioned, all club funds, whether they are derived from dues or fund-raising, must be used for tax-exempt purposes only. These tax-exempt purposes may include the following:

- building and improving clubs;
- training club and district officers;
- purchasing educational program materials;
- sending a voting delegate to official district conferences or the international convention; or
- covering general administrative expenses connected with the operation of the club or district.

If you wish to hold a fund-raiser, consider the following activities:

- Conducting a Speechcraft, Success/Communication, or Success / Leadership program and charging a reasonable fee to participants. Revenues would be used to purchase the program material, with any excess funds to be returned to the club or district.
- Holding a raffle, auction, white elephant sale, or bazaar of donated goods, with the revenues going to further the educational objectives of Toastmasters International.
- Accepting advertising in your club or district newsletter, with the revenue being used to offset newsletter production or mailing costs.
- Creating and maintaining a speakers bureau, with the revenues being used at club and/or district levels for the purpose of furthering Toastmasters International.

Some fund-raising activities such as picnics, sporting events, and fireworks displays have a high risk of injury and are not permitted. In the event you do consider holding a fund-raising event, begin by referring to the treasurer handbook (Catalog No. 1310F) for further information about these guidelines.

PRESENTER: Take a few minutes to ask your audience about their individual budget objectives and what type of income sources they plan to employ.

Provide the bank with a new signature card by July 1/January 1.

Before writing checks on the club's account, you must provide the bank with a new signature card authorizing withdrawals over your signature and that of the new club president. Ask your bank for the proper form to complete. Avoid changing banks unnecessarily. If the bank location is inconvenient for you, consider depositing by mail or at another bank branch. And be sure to advise the bank that Toastmasters International is a nonprofit, tax-exempt organization; some banks will waive their fees.

Apply for a debit card so you can submit transactions to WHQ electronically.

Each club in the United States must have an Employer Identification Number in order to qualify for tax-exempt status. If your club does not have such a number, one can be obtained by filing a Form SS-4 with the Internal Revenue Service. Be sure World Headquarters has your club's identification number on file.

Prepare and send dues statements by August 15/February 15. Twice each year your club must submit \$27 dues (\$21.50 dues for undistricted clubs) to World

HO #2

Headquarters for each member of your club. You are responsible for notifying members in writing of dues payable using the Statement of Club Dues form (Catalog No. 36). Indicate on the statement that all checks should be payable to the club. The club should then issue one check payable or submit one credit card number to Toastmasters International.

Collect and send dues to World Headquarters by October 1/April 1, and work with the vice president membership to contact members who have not paid dues. Allow plenty of time to collect dues. The club president will receive forms in early September and early March, but don't wait until the day they arrive to get started; begin collecting dues before that time. Make an announcement at your meeting, and work with the vice president membership to contact members who have not attended for awhile. Send a second reminder within a week or two.

When members pay their dues, give them a receipt (Catalog No. 37) and record the payment in the club's ledger or in the Membership Roster and Record of Dues Paid (Catalog No. 82). Regularly deposit these payments into the club's bank account.

Once your club's president receives the Dues Renewal Invoice from World Headquarters in early September and early March, help the president and other

officers complete the invoice based on your record of payments received. Double check your work; an accurate membership report is important. Accidentally omitting someone from the list who did indeed pay dues jeopardizes that person's eligibility for educational awards and speech contests and that person will no longer receive *The Toastmaster* magazine. A wrong address will delay receipt of the magazine.

Be careful about sending dues for people who have not paid the club. Don't assume these people will renew their membership; if they don't, your club loses the money. You can pay dues for late-paying members anytime during the renewal period. Be sure you keep a copy of the completed Dues Renewal Invoice.

When the Dues Renewal Invoice is completed, submit the dues renewal online, if paying by credit card or write a check payable to Toastmasters International (US funds). When paying by credit card please use one card for the entire transaction (MasterCard, VISA, Discover, and American Express credit cards are accepted.)

When members pay their dues after the report has been mailed, submit the dues online for those late-paying members if paying by credit card, OR send a check payable to Toastmasters International or credit card information for the amount due and a letter that includes the following:

- ❑ the names and addresses of the members for whom you are paying dues,
and

- ❑ a statement that these are continuing members who paid their dues after the dues renewal was submitted.
- ❑ If using a copy of the Dues Renewal Invoice, be sure it is clearly marked which members are being paid with this transaction.

Submit new member applications and dues to World Headquarters within 48 hours after receipt. Once you have received all dues and fees from new members, submit information online if paying by credit card or write a check payable or send credit card payment information to Toastmasters International for the full amount due. Payments on behalf of more than one member can be included in the check or credit card. Do not enclose new member dues and applications with the dues renewal. Be sure to put your club and district numbers on all payments and correspondence to Toastmasters International.

Pay all bills promptly. Membership dues and fees are billed and paid through a club account. Product orders are billed and paid by individual members. When you or your club need to order supplies from World Headquarters, submit the order online if paying by credit card or write a check or submit credit card information for the proper amount and send it with the order form.

T-V #2

Your club president will receive a monthly statement. Be sure you obtain these statements from your president and review them; if your club owes money, it is due immediately. If you have any questions about your club's account, contact World Headquarters at statements@toastmasters.org.

When your club receives bills from World Headquarters or other vendors, review each bill for accuracy with the club president and then authorize payment by initialing and dating the invoice. Pay all bills promptly by check or credit card so you have a record of all transactions. Be sure to write the check number and date on the invoice and file it in a "bills-paid" file.

Payment involving meals, rent for your meeting place, or other recurring bills may be authorized in advance by the executive committee and should be paid immediately.

Keep records of all financial transactions. Clear, complete, and accurate records are invaluable. They will help keep your club updated on its financial standing so any necessary adjustments to club expenditures can be made.

Each month reconcile deposits, expenditures, and cash on hand. The club checking account record can help you; Toastmasters International also has several

record keeping forms that can be of assistance, including the Cash Receipts and Disbursements Journal (Catalog No. 81) and Membership Roster and Record of Dues Paid (Catalog No. 82).

Since Toastmasters International is a nonprofit organization, do not file income tax reports unless your club's yearly income is greater than \$25,000. If you receive an Internal Revenue Service inquiry and your income is less than \$25,000, write "Gross Income Under \$25,000" across the form and return it to the IRS by the deadline.

As indicated earlier, if your club is located in the United States, your bank probably requires an Employer's Identification Number for your club account. If your club does not already have an Employer Identification Number, you can request one from the Internal Revenue Service by filing Form SS-4. The number you receive is a permanent number for all club accounts. Notify World Headquarters of your number immediately; World Headquarters will keep it in your club's file.

Present verbal and written financial reports. As treasurer, you must keep the club's officers and membership apprised of the club's finances. At the first meeting of each month, present a verbal report of the club's finances to the club and give a

written copy to the executive committee. Your report should include the names of any members who have not paid for the current period.

Submit club accounts for audit. As in any organization, your club's financial records need to be audited periodically to verify their correctness. This should be done at the end of your term by three club members who are not part of the executive committee. Be sure to have all records, receipts, and invoices organized for the auditors.

Arrange for a replacement. Occasionally you may not be able to attend a club meeting or you know you will be late. In these cases, arrange for someone to handle your responsibilities for you. This will help the club to function smoothly.

Prepare your successor for office. As you gain experience during your term, take notes and think of how you will prepare the person who will come after you. Give all necessary records and materials to your successor and offer to assist the new officer as he or she is learning the treasurer's duties.

Standards at the Club Meeting

T-V #3

Your standards at the club meeting include:

Receive completed new member applications and dues. As mentioned earlier, when new members and continuing members pay their dues, give them a receipt

(Catalog No. 37) and record the payment in the club's ledger or in the Membership Roster and Record of Dues Paid (Catalog No. 82). Regularly deposit these payments into the club's bank account.

Announce when dues are due and explain dues structure. Remind club members to pay their dues and tell them how much each member owes. The amount owed should cover the \$27 (\$21.50 for clubs not assigned to districts) due World Headquarters, plus whatever fees are charged by the club. All checks should be payable to the club. You may want to review what benefits members receive from the club and what expenses their dues covers.

Greet members and guests. The sergeant at arms is the official "greeter" at club meetings, but all members and officers should welcome visitors and fellow members to the meeting. This creates a friendly and comfortable atmosphere.

***PRESENTER:** Distribute Resource List, Handout #4. Hold a discussion about what supplies the treasurer might find useful.*

RESOURCES

- Supply Catalog (Catalog No. 1205) and order forms (Catalog No. 1205A) – Sent to the club in January.
- Treasurer Handbook (Catalog No. 1310F) – Sent to the club in May.
- Distinguished Club Program/Club Success Plan (Catalog No. 1111) – Sent to the club in May.
- Application for Membership (Catalog No. 400) – Sent to the club quarterly.
- Cash Receipts and Disbursements Journal Sheet (Catalog No. 81) – Available through the supply catalog.
- Statement of Club Dues (Catalog No. 36) – Available through the supply catalog.
- Club Dues Receipt Pad (Catalog No. 37) – Available through the supply catalog.
- Membership Roster and Record of Dues Paid (Catalog No. 82) – Available through the supply catalog.
- Portable File Case (Catalog No. 1329) – Available through the supply catalog.
- *The Toastmaster* and *TIPS* – *The Toastmaster* magazine is published monthly and is sent to all Toastmasters; *TIPS* is a bimonthly publication emailed to most club officers.

HO #4

NOTES

PRESENTER: Continue with the following case studies. The participant's sections of these case studies are included in Part III for copy and distribution. Afterward, if you have time, answer questions and perhaps give a short motivational closing.

HO #5, #6

CASE STUDY #1

*Case Study for Club Treasurers:**When Participants Fail to Pay*

Objective: Identify ways to have members pay dues on time and determine how to deal with those who will not.

Time: 15 minutes

Process:

- 1. Distribute the case study sheet in Part III to the training session participants.*
- 2. Ask the participants to analyze the situation and formulate some solutions.*
- 3. Ask the group as a whole how to resolve the issue; record responses on a flip chart.*

Recommended Solutions:

- After giving members repeated reminders, state that when their payment is delinquent, your duty as a treasurer is to notify World Headquarters. In turn, World Headquarters will remove their names from the club's membership roster, and the members will no longer receive the magazine or any other materials.*
- If a member has not paid and still shows up at meetings, you can vote that person out and disallow further participation in club activities. CAUTION: This can be a very sensitive issue, so it's imperative you consult the club president's handbook for the correct procedure.*



Case Study for Club Treasurers:***When Dues Are Due***

Objective: *To determine the amount of membership dues that will be submitted with a Dues Renewal Invoice.*

Time: *15 minutes*

Process:

- 1. Distribute copies of the case study sheet in Part III.*
- 2. Ask the participants individually to diagnose the case and arrive at some solutions.*
- 3. Ask the group as a whole how they would resolve the issue.*

Recommended Solution:

- The club should submit \$216 dues for 8 members. James Davidson, Ted Franks and Elena Petrovski have not paid dues and the boxes next to their names should not be checked. Elizabeth Buchwald and Arturo Gonzalez's names and addresses should be added to the list and their dues should be included, James Bond's address should be marked out and his new one written in if submitting by mail, or an e-mail sent to addresschanges@toastmasters.org with the address change.*



PART III: HANDOUTS

The following handouts may be reproduced for distribution to your training session participants. Make certain you accurately project the number of attendees so you have enough.

Feel free to revise the material to suit your own style.

TREASURER STANDARDS

Outside of the club meeting...

1. Prepare a budget to be approved by the executive committee and membership within one month of taking office.
2. Provide the bank with a new signature card by July 1/January 1.
3. Prepare and send dues statements by August 15/February 15.
4. Collect and send dues to World Headquarters by October 1 and April 1, and work with the vice president membership to contact members who have not paid dues.
5. Submit new member applications and dues to World Headquarters within 48 hours after receipt.
6. Pay bills as due.
7. Keep records of all financial transactions.
8. Present verbal and written financial reports quarterly (October 15, January 15, April 15, and July 15).
9. Submit club accounts for audit.
10. Attend club executive committee meetings.
11. Attend district-sponsored club officer training.
12. Arrange for a replacement if unable to attend meeting.
13. Prepare successor for office.

Standards at the club meeting...

1. Receive completed new member applications and dues.
2. Announce when dues are due and explain dues structure.
3. Greet members and guests.

SAMPLE DUES STATEMENT

Date Oct. 1 20 99

Morning

Toastmasters Club No. 9999

To: Sally Smith

8888 Main Street

Anytown, MA 22222

Make Check Payable To: Morning Toastmasters Club

MAIL TO: Walter Clark, Treasurer

P.O. Box 3333

Anytown, MA 22222

FOR:

Membership Dues:

From April 20 99 to September 20 99 \$ 27.00

Initiation Fee _____ \$ _____

Meals April and May \$ 27.00

Other _____ \$ _____

TOTAL \$ 54.00

FORM NO. 36

SAMPLE TREASURER'S REPORT

TOASTMASTERS CLUB TREASURER'S REPORT

FOR THE MONTH OF _____

CASH BALANCE, BEGINNING OF MONTH	\$103.56
----------------------------------	----------

CASH RECEIVED:

DUES	9.50
------	------

CASH SPENT:

MEALS	65.00
-------	-------

POSTAGE	2.60
---------	------

CASH BALANCE, END OF MONTH	\$ 45.46
----------------------------	----------

RESOURCES LIST

Achieving Success as Treasurer

Following are some materials you may want to order to ensure a successful term as Treasurer:

Quantity			Total
_____	1310F	Treasurer Handbook	\$2.50 \$_____
_____	1111	Distinguished Club Program/Club Success Plan	\$1.25 \$_____
_____	400	Application for Membership	N/C \$_____
_____	36	Statement of Club Dues	\$2.00 \$_____
_____	37	Club Dues Receipt Pad	\$2.25 \$_____
_____	81	Cash Receipts and Disbursements	
		Journal Sheet	\$.75 \$_____
_____	82	Membership Roster and Record of Dues Paid	\$.75 \$_____
_____	1205	Supply Catalog	\$1.00 \$_____
_____	1329	Portable File Case...12" x 9½" x 9½" plastic file case for storing club information and records	\$29.95 \$_____
			TOTAL \$_____

S & H = Shipping and handling

CA clubs add 7.75% \$_____

TOTAL AMOUNT

\$_____

Mail to: Toastmasters International
 P.O. Box 9052, Mission Viejo, CA 92690 U.S.A.
 or telephone (949) 858-8255 Fax No: (949) 858-1207

Standard Domestic Shipping Prices - 2006					
TOTAL ORDER		SHIPPING CHARGES	TOTAL ORDER		SHIPPING CHARGES
\$0.00 to	\$2.50	\$1.80	35.01 to	50.00	\$7.90
2.51 to	5.00	3.45	50.01 to	100.00	9.15
5.01 to	10.00	4.15	100.01 to	150.00	12.15
10.01 to	20.00	4.90	150.01 to	200.00	15.15
20.01 to	35.00	6.90	200.01 to	—	Add 10% of total price

For orders shipped outside the United States, see the current Supply Catalog for item weight and shipping charts to calculate the exact postage. Or, estimate airmail at 35% of order total, though actual charges may vary significantly. Excess charges will be billed. All prices subject to change without notice.

PAYMENT MUST ACCOMPANY ORDER

_____ Enclosed is my check in the amount of \$_____ (U.S.) or

_____ Please bill against my MasterCard/VISA/Discover/AMEX (Circle one)

Credit Card No. _____ Expiration Date _____

Signature _____

Name _____

Club No. _____ Club Name _____

Address _____

City _____ State/Province _____

Country _____ Postal Code _____

Email _____ Phone No. _____

Order online at www.toastmasters.org

CASE STUDY #1

CASE STUDY FOR TREASURERS: WHEN PARTICIPANTS DO NOT PAY

Two weeks ago you sent dues statements to all of your club members. Everyone has paid – except for Don Delinquent. You have reminded Don at each meeting, yet he still has not submitted his payment. And now your dues renewal is due! How should you deal with Don Delinquent?

CASE STUDY #2

CASE STUDY FOR TREASURERS: WHEN DUES ARE DUE

Your president has received the Dues Renewal Invoice for October-March sent by World Headquarters. Now you are meeting with the president, vice president membership, and secretary to update the report. Using the following information, complete the invoice and determine the amount of dues (\$27 per member) to submit with your club's report.

- Two people, Elizabeth Buchwald and Arturo Gonzalez, joined your club in September. Their names are not on the printed list you received from World Headquarters. Your vice president membership has already mailed the Applications for Membership, new member fees, and dues for September to World Headquarters.
- Two people, James Davidson and Ted Franks, have told your vice president membership they no longer will be participating in the club.
- One person, Elena Petrovski, has not yet paid dues to the treasurer.
- One person, James Bond, has a new address: 123 Pontificate Place, Oakdale, CA.

DUES RENEWAL INVOICE



Toastmasters Club
1355 Smedley Dr
Oakdale, CA 95361

TOASTMASTERS INTERNATIONAL
Mail Address:
PO Box 9052
Mission Viejo, CA 92690

Courier Address:
TOASTMASTERS INTERNATIONAL
23182 Arroyo Vista
Rancho Santa Margarita, CA 92688

PHONE: 949.858.8255 - FAX: 949.858.1207

For dues period
October 1, 2004 -
March 31, 2005

URGENT!
DUE OCTOBER 1

9999
Toastmasters Club

Invoice Date: 08/18/2004

*Please make corrections to a member's address on this invoice.
Dues are payable in advance and are non-refundable and non-transferable.*

CHECK IF RENEWING	MEMBER NUMBER	MEMBER NAME AND ADDRESS	DUES AMOUNT	ORDER NUMBER
<input type="checkbox"/>	99299829	James Bond 812 Toastmasters St Oakdale, CA 95361	\$ 27.00	2999741288
<input type="checkbox"/>	99320332	Joan Botsko, ATMB 2243 Toastmasters Rd Oakdale, CA 95361	\$ 27.00	2999741289
<input type="checkbox"/>	99314236	James Davidson, CTM 230 Toastmaster Dr Oakdale, CA 95361-1234	\$ 27.00	2999741295
<input type="checkbox"/>	99299831	Daphne Duck, DTM 1188 Toastmasters Ave Oakdale, CA 95361	\$ 27.00	2999741291
<input type="checkbox"/>	990313207	Ted Franks, CL 998 Toastmasters Ct Oakdale, CA 95361	\$ 27.00	2999741292

<input type="checkbox"/>	99299833	Jacqueline Jacob, ATM 1401 Toastmasters Cir Oakdale, CA 95361	\$ 27.00	2999741293
<input type="checkbox"/>	99299834	Joseph Peters, DTM 9707 Toastmasters Blvd Oakdale, CA 95361	\$ 27.00	2999741297
<input type="checkbox"/>	99647974	Elena Petrovski, AL 400 Toastmasters Ln Oakdale, CA 95361-9468	\$ 27.00	2999741298
<input type="checkbox"/>	99311210	Neil Tip, CTM 26754 Toastmasters Aly Escalon, CA 95320	\$ 27.00	2999741294

No. of Members Renewing _____ Amount Due: \$ _____

Payment Information: Check No. _____ Check Amount: \$ _____ (U.S.FUNDS)

Credit Card MC VISA American Express Discover

Please use only one card for the entire transaction. Multiple credit cards cannot be accepted.

Credit Card No. _____ Credit Card Amount: \$ _____

Expiration Date: _____ Signature: _____

Name as it appears on Credit Card: _____

Other _____

If paying by check, please mail the invoice and check (U.S.FUNDS) to Toastmasters International. If paying by credit card, please either mail, fax or e-mail this invoice and payment information to Toastmasters International. To avoid duplication, please submit this information by one method only. It is not necessary to mail and FAX the information to us. Our post office address, street address (for courier and UPS submissions) and fax number are at the top of this invoice.

Form Prepared By: _____

NAME _____ OFFICER TITLE _____

E-MAIL ADDRESS _____ TELEPHONE NO. _____

Pay This Renewal Online
 Login to www.toastmasters.org/renew

EVALUATION FORM

Date: _____ Program Name: _____

Facilitator: _____

On a scale of one to five, five being the highest rating, please rate the course and facilitator on the following items by circling the number you find most appropriate:

1. How relevant was this session to your job in Toastmasters?
1 2 3 4 5

2. Rate the following:
Course content 1 2 3 4 5
Course material 1 2 3 4 5
Facilitator 1 2 3 4 5
Activities/exercises 1 2 3 4 5

3. Were the objectives clearly stated?
1 2 3 4 5

4. How was the lesson plan organized?
1 2 3 4 5

5. Did the instructional methods clearly illustrate the instructor's plan?
1 2 3 4 5

6. To what extent did the visual aids add to your understanding of the presentation?
1 2 3 4 5

7. How were the meeting facilities?
1 2 3 4 5

8. What are two things you learned that will make you a more effective club officer?

Additional Comments:

PART IV:

VISUAL AIDS COPY FOR THE TRAINING SESSION

Materials on the following pages are designed specifically for the presenter to use in conducting the training session. You can reproduce them as transparencies for use on an overhead projector, or handwrite them on a flip chart. If you will be using a laptop computer, data projector and screen, PowerPoint visuals are available on the TI Web site.

In the right-hand column are keys for visual aids. Their placement indicates the points at which they should be displayed. Each is numbered. For example, **T-V #1** stands for “the first visual.” You also may use the right-hand margin for making notes.

TIPS ON USE:

1. **Show the visual aid only while you are talking about it.**
2. **Be sure everyone in the audience can see the visuals clearly.** Visibility to the people at the rear of the room is your guide.
3. **Talk to the audience, not to the visual.** Maintain eye contact even when your listeners are looking at the visual. This will help you judge their understanding.
4. **Don't overdo it.** You need not illustrate every point in the speech.
5. **Rehearse.** Nothing is more important than adequate preparation. Know how and when you will use the visual, and practice so you will make a smooth presentation. Anticipate all possible problems, especially when electronic equipment is involved.
6. **Remember . . .** Be as professional as possible.

Standards Outside of Meeting

- Prepare budget
- Provide bank with signature card
- Prepare / send dues statement
- Collect / submit dues to WHQ online
- Submit applications / dues to WHQ online

- Pay bills as due
- Keep records
- Present verbal / written reports
- Submit accounts for audit
- Arrange for replacement
- Prepare your successor

Standards at the Meeting

- Receive applications / dues
- Announce dues are due
- Greet members / guests